



Specification

KWT722

SSC		CUSTOMER
Drawn	Approval	Approval

CONTENTS

1. Feature & Application
2. Absolute Maximum Ratings
3. Electro Characteristics
4. Optical characteristics
5. Color & Binning
6. Rank of KWT722
7. Outline Dimension
8. Packing
9. Soldering
10. Precaution for use
11. Reliability Test Item and Condition

KWT722

Description

This surface-mount LED comes in PLCC standard package dimension. It has a substrate made up of a molded plastic reflector sitting on top of a bent lead frame. The die is attached within the reflector cavity and the cavity is encapsulated by epoxy or silicone.

The package design coupled with careful selection of component materials allow these products to perform with high reliability in a larger temperature range -40°C to 100°C . The high reliability feature is crucial to Automotive interior and Indoor ESS.

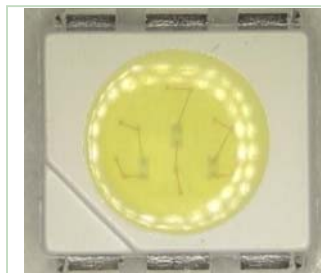

KWT722

Features

- White colored SMT package.
- Material : InGaN/SiC
- Encapsulating Resin : Epoxy Resin
- Suitable for all SMT assembly methods ; Suitable for all soldering methods
- RoHS Compliant

Applications

- Interior automotive
- Office Automation, Electrical Appliances, Industrial Equipment
- Lightings

2. Absolute maximum ratings

Parameter	Symbol	Value	Unit
Power Dissipation	P_d	350	mW
Forward Current	I_F	90	mA
Peak Forward Current	I_{FM}^{*2}	270	mA
Reverse Voltage (per die)	V_R	5	V
Operating Temperature	T_{opr}	-30 ~ +85	°C
Storage Temperature	T_{stg}	-40 ~ +100	°C

*1 Care is to be taken that power dissipation does not exceed the absolute maximum rating of the product.

*2 I_{FM} was measured at $T_w \leq 1$ msec of pulse width and $D \leq 1/10$ of duty ratio.

3. Electric & Optical characteristics

Parameter	Symbol	Condition	Min	Typ	Max	Unit
Forward Voltage (per die)	V_F	$I_F = 20$ mA	2.7	3.2	3.7	V
Reverse Current (per die)	I_R	$V_R = 5$ V	-	-	50	μ A
Luminance Intensity *1	I_V	$I_F = 60$ mA	3000	4800	6000	mcd
Luminance Flux	Φ_V	$I_F = 60$ mA	-	13	-	lm
Color Temperature	CCT	$I_F = 60$ mA	4800	-	12000	K
Color Coordinate	X	$I_F = 60$ mA	-	0.31	-	-
	Y		-	0.31	-	
Viewing Angle *2	$2\theta_{1/2}$	$I_F = 60$ mA	-	120	-	deg
Optical Efficiency	η_{op}	$I_F = 60$ mA	-	68	-	lm/W

*1. The luminous intensity I_V was measured at the peak of the spatial pattern which may not be aligned with the mechanical axis of the LED package. Luminous Intensity Measurement allowance is $\pm 10\%$

*2. $2\theta_{1/2}$ is the off-axis where the luminous intensity is 1/2 of the peak intensity.

[Note] All measurements were made under the standardized environment of SSC.

4. Optical characteristics

Forward Current vs. Forward Voltage (per die)

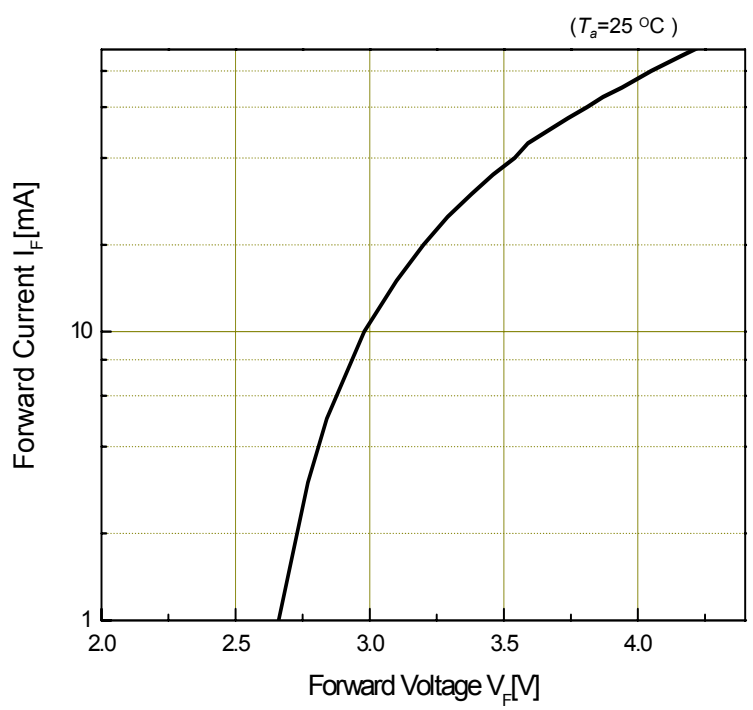

Relative Luminous Intensity vs Forward Current

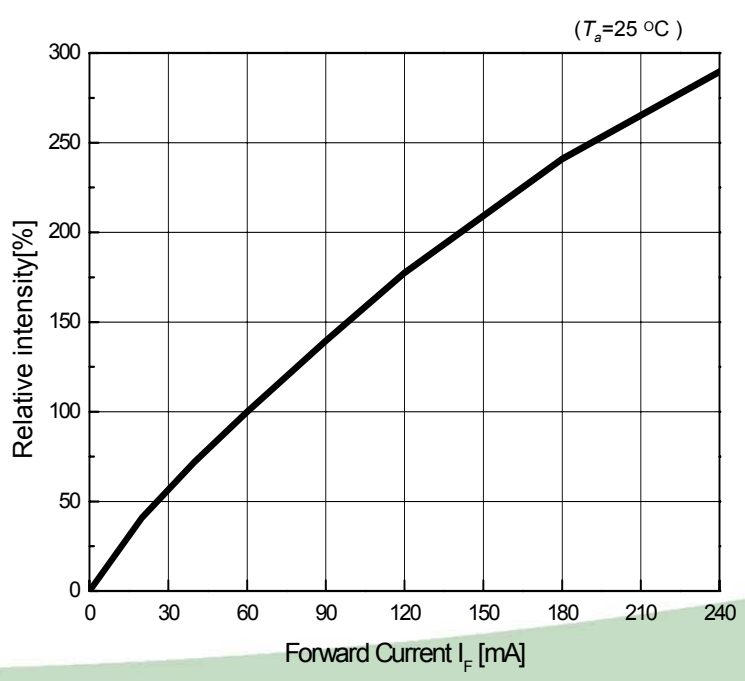

4. Optical characteristics

Ambient Temperature vs. Allowable Forward Current (per die)

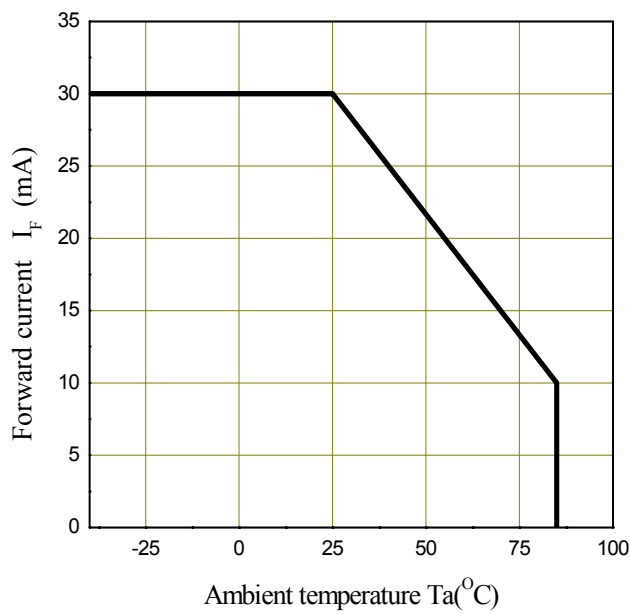

Radiation Diagram

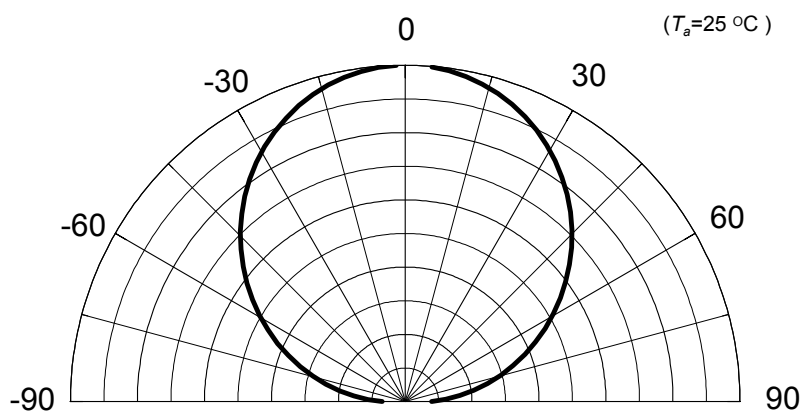

4. Optical characteristics

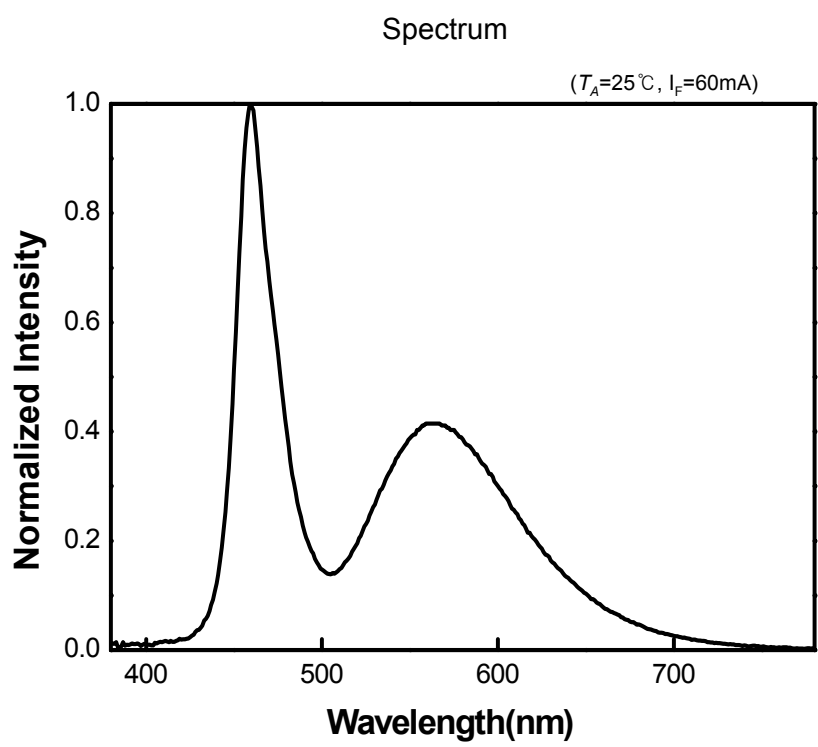

5. Color & Binning

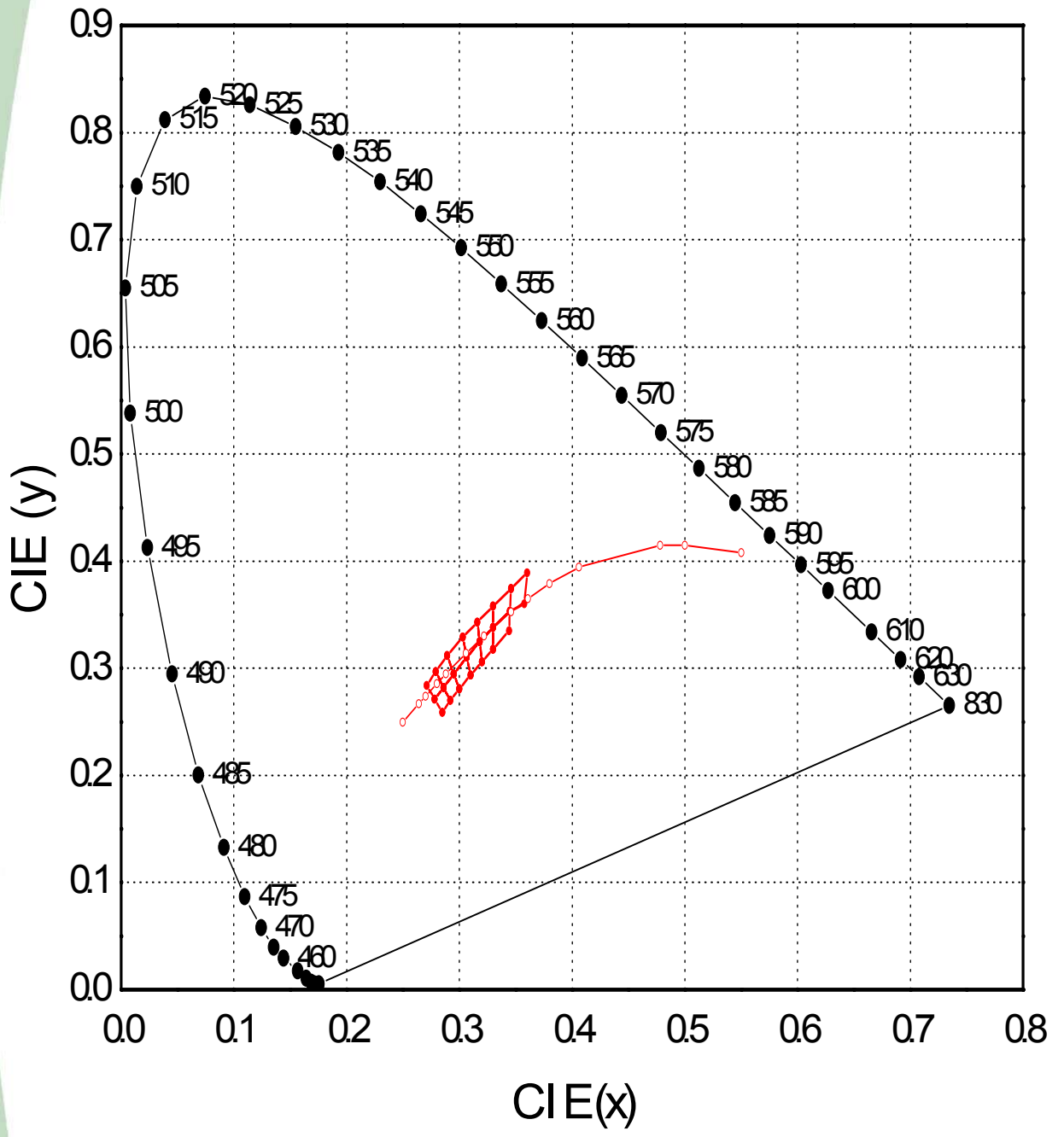

5. Color & Binning

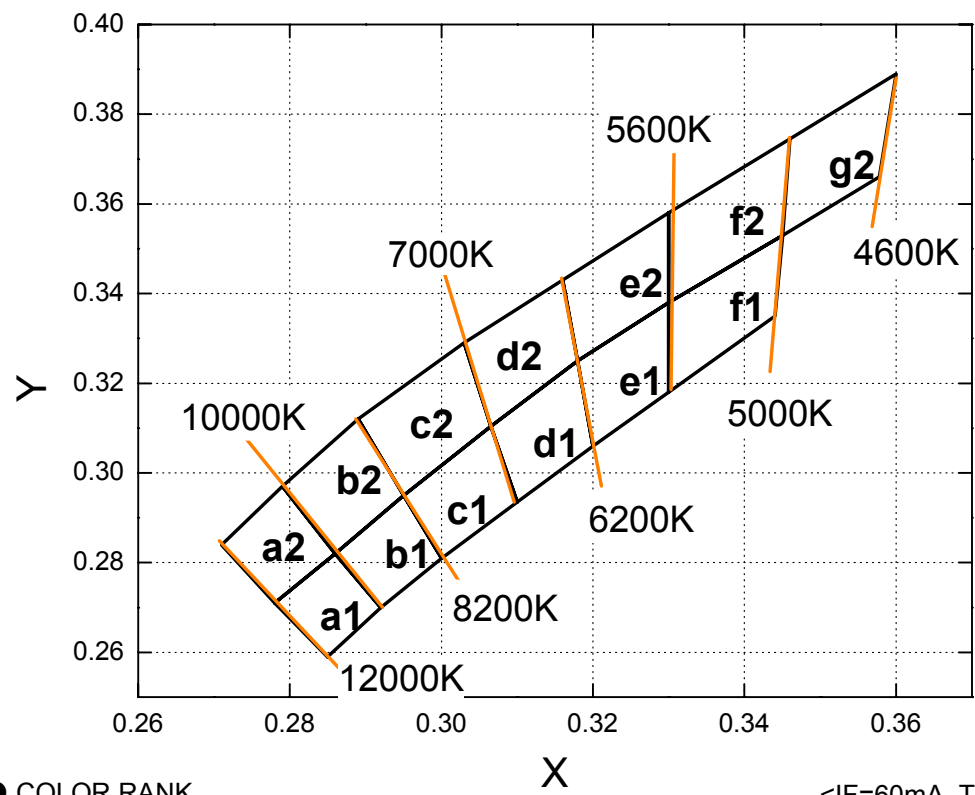

● COLOR RANK

<IF=60mA, Ta=25°C>

a1		a2		b1		b2			
X	Y	X	Y	X	Y	X	Y		
0.285	0.259	0.278	0.271	0.292	0.27	0.286	0.282		
0.292	0.27	0.286	0.282	0.3	0.281	0.295	0.295		
0.286	0.282	0.279	0.297	0.295	0.295	0.289	0.312		
0.278	0.271	0.271	0.284	0.286	0.282	0.279	0.297		
c1		c2		d1		d2			
X	Y	X	Y	X	Y	X	Y		
0.3	0.281	0.295	0.295	0.31	0.2935	0.3065	0.3104		
0.31	0.2935	0.3065	0.3104	0.32	0.306	0.318	0.325		
0.3065	0.3104	0.303	0.329	0.318	0.325	0.316	0.343		
0.295	0.295	0.289	0.312	0.3065	0.3104	0.303	0.329		
e1		e2		f1		f2		g2	
X	Y	X	Y	X	Y	X	Y	X	Y
0.32	0.306	0.318	0.325	0.33	0.318	0.33	0.338	0.346	0.3745
0.33	0.318	0.33	0.338	0.344	0.335	0.345	0.353	0.36	0.389
0.33	0.338	0.33	0.358	0.345	0.353	0.346	0.374	0.3578	0.36
0.318	0.325	0.316	0.343	0.33	0.338	0.33	0.358	0.345	0.353

* Measurement Uncertainty of the Color Coordinates : ± 0.01

6. rank of KWT722

Rank Name Table

X_1	X_2	X_3
VF	IV	CIE

Forward Voltage [V]

Rank Name	MIN	MAX
Y	2.9	3.1
Z	3.1	3.2
Z1	3.2	3.3
A	3.3	3.5

Luminous Intensity [mcd]

Rank Name	MIN	MAX
R	3000	4000
S	4000	6000

7.outline dimension

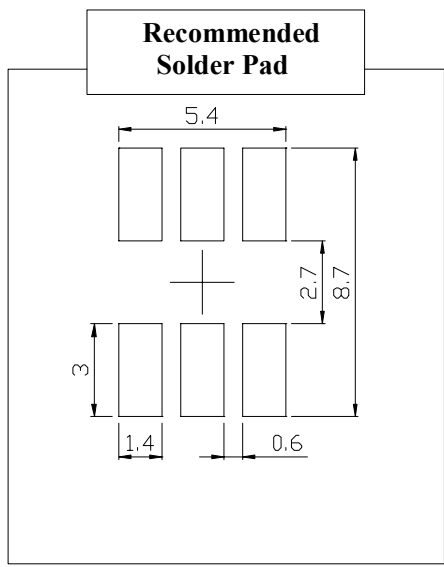
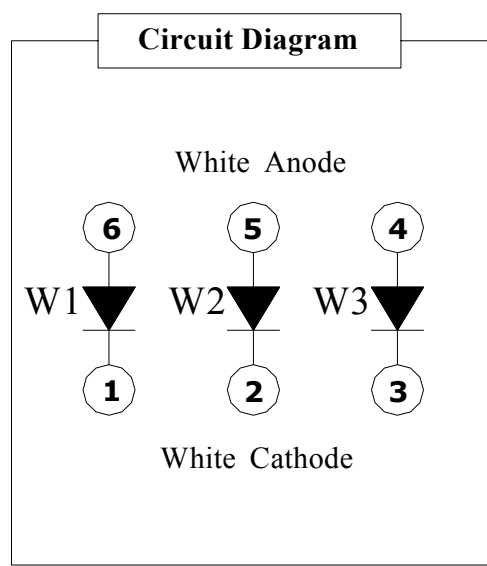
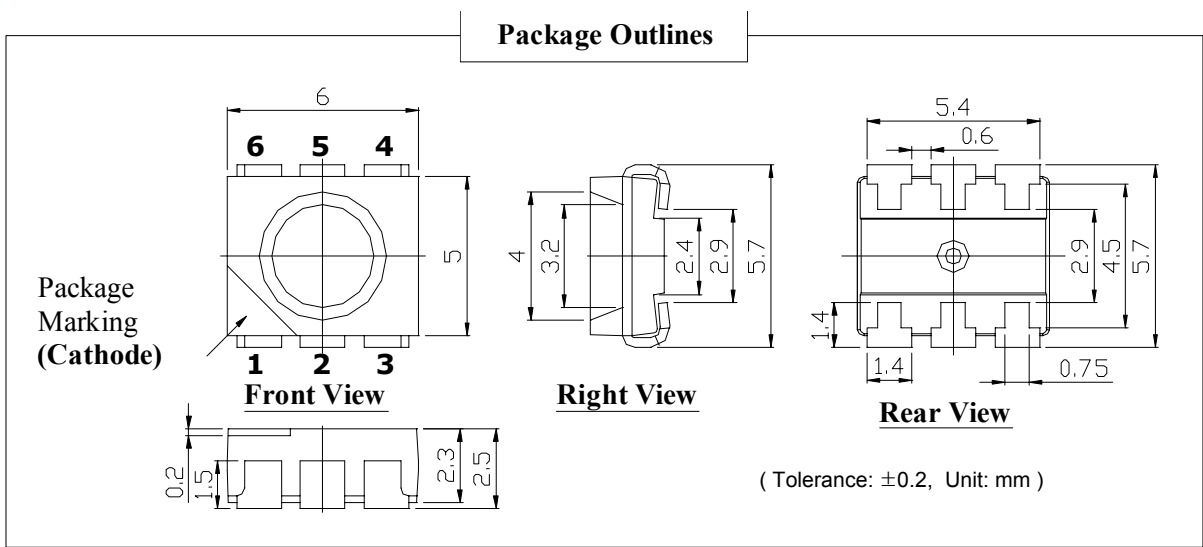

*** MATERIALS**

PARTS	MATERIALS
Package	Heat-Resistant Polymer
Encapsulating Resin	Epoxy Resin
Electrodes	Ag Plating Copper Alloy

8. packing

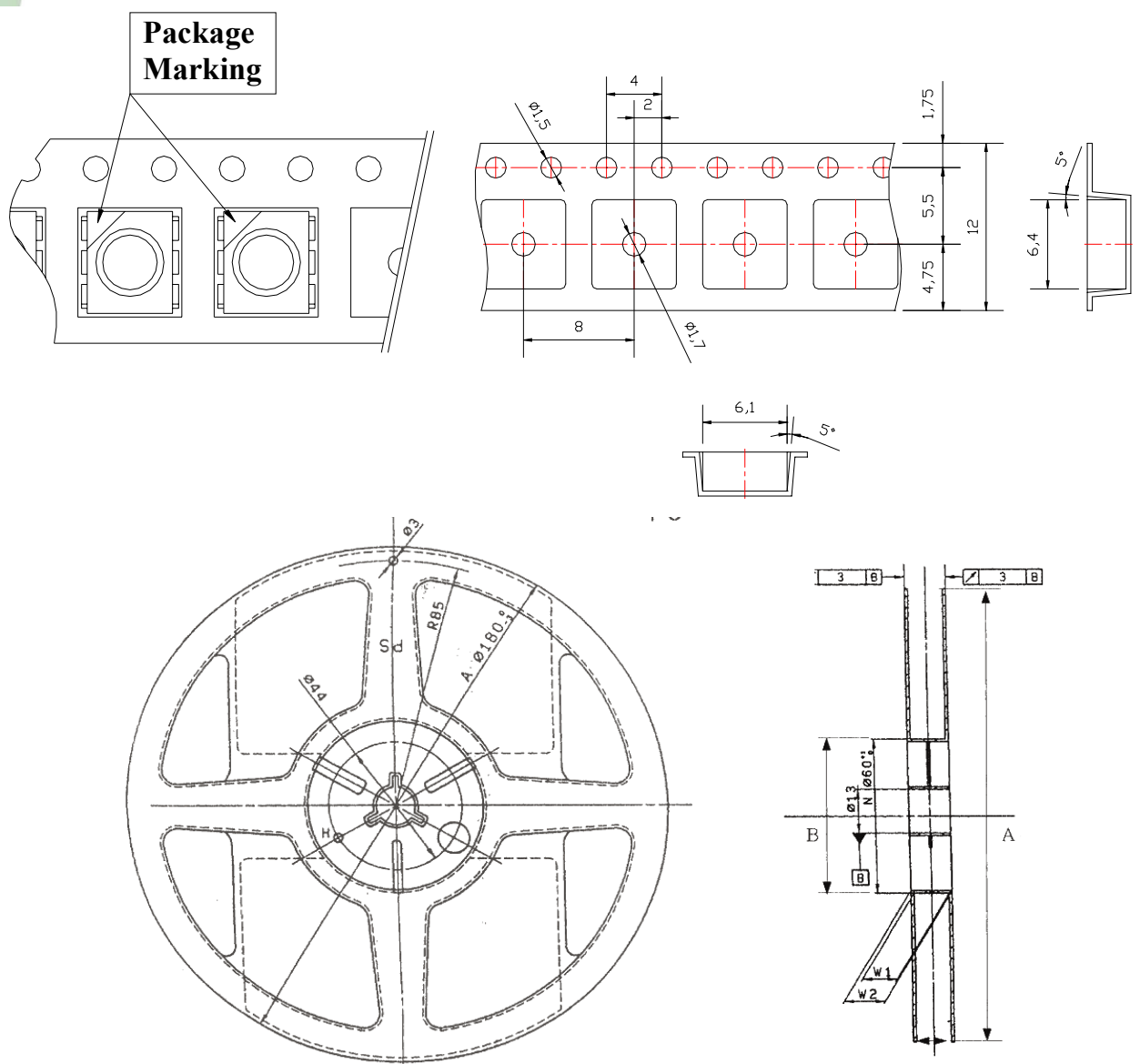

(Tolerance: ± 0.2 , Unit: mm)

- 1)Quantity : 700pcs/Reel
- 2)Cumulative Tolerance : Cumulative Tolerance/10 pitches to be ± 0.2 mm
- 3)Adhesion Strength of Cover Tape : Adhesion strength to be 0.1-0.7N when the cover tape is turned off from the carrier tape at the angle of 10 to the carrier tape
- 4)Package : P/N, Manufacturing data Code No. and quantity to be indicated on a damp proof Package

Rev. 00

November 2007

www.ZLED.com

● Reel Packing Structure

Reel

RANK: XXXX
 QUANTITY: XXXX
 LOT NUMBER: XXXXXXXXXXXX
 PART NUMBER: XXXXXXXX
 SEOUL SEMICONDUCTOR CO., LTD.

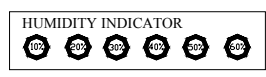
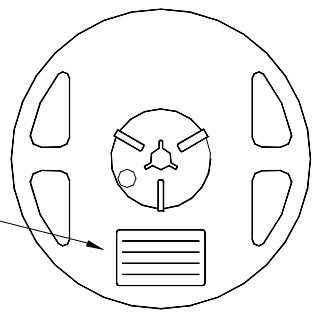

Aluminum Vinyl Bag

RANK: XXXX
 QUANTITY: XXXX
 LOT NUMBER: XXXXXXXXXXXX
 PART NUMBER: XXXXXXXX
 SEOUL SEMICONDUCTOR CO., LTD.

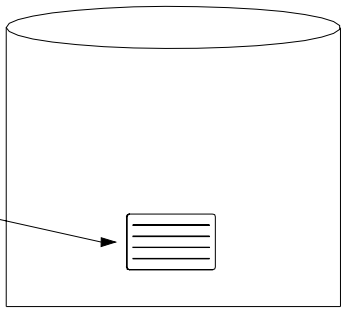

Outer Box Structure

Material : Paper(SW3B(B))

TYPE	SIZE (mm)		
	Ⓐ	Ⓑ	Ⓒ
7inch	245	220	102
	245	220	142

① SIDE

RANK: XXXX
 QUANTITY: XXXX
 LOT NUMBER: XXXXXXXXXXXX
 PART NUMBER: XXXXXXXX
 SEOUL SEMICONDUCTOR CO., LTD.

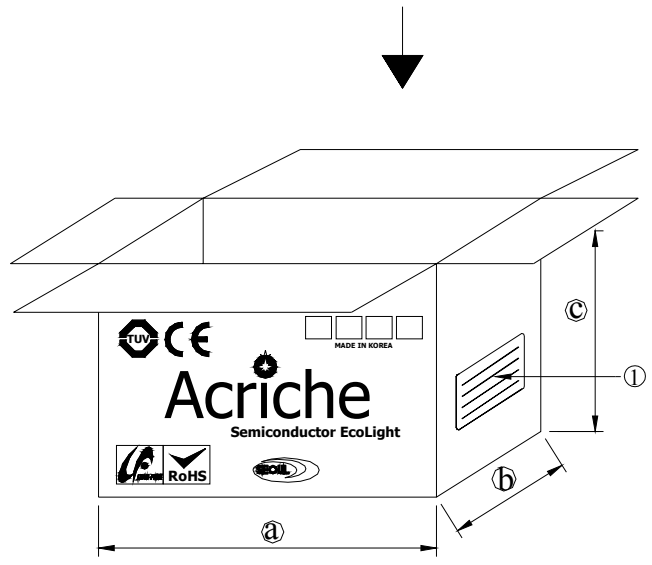

9. soldering

(1) Lead Solder

Lead Solder	
Pre-heat	120~150 °C
Pre-heat time	120 sec. Max.
Peak-Temperature	240 °C Max.
Soldering time Condition	10 sec. Max.

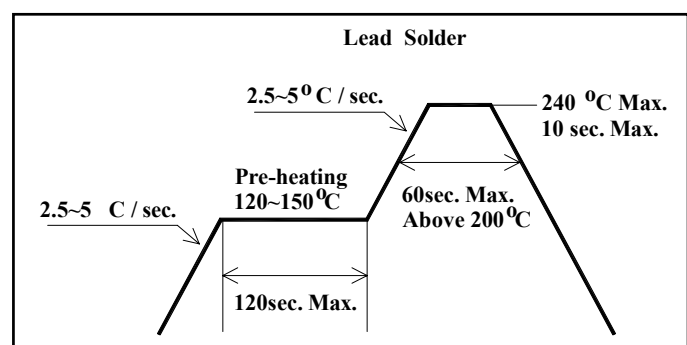

(2) Lead-Free Solder

Lead Free Solder	
Pre-heat	150~200 °C
Pre-heat time	120 sec. Max.
Peak-Temperature	260 °C Max.
Soldering time Condition	10 sec. Max.

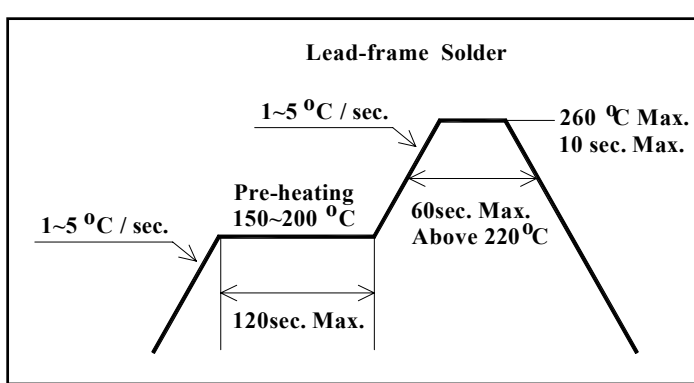

(3) Hand Soldering conditions

Do not exceed 4 seconds at maximum 315°C under soldering iron.

(4) Reflow soldering should not be done more than three times.

Note : In case that the soldered products are reused in soldering process, we don't guarantee the products.

10. precaution for use

(1) Storage

In order to avoid the absorption of moisture, it is recommended to store in a dry box (or a desiccator) with a desiccant. Otherwise, to store them in the following environment is recommended.

Temperature : 5°C ~30°C Humidity : maximum 65%RH

(2) Attention after open.

LED is correspond to SMD, when LED be soldered dip, interfacial separation may affect the light transmission efficiency, causing the light intensity to drop. Attention in followed;

a. After opened and mounted the soldering shall be quickly.

b. Keeping of a fraction

Temperature : 5 ~ 40°C Humidity : less than 10%

(3) In the case of more than 1 week passed after opening or change color of indicator on desiccant, components shall be dried 10-12hr. at 60±5°C.

(4) Any mechanical force or any excess vibration shall not be accepted to apply during cooling process to normal temperature after soldering.

(5) Quick cooling shall be avoided.

(6) Components shall not be mounted on warped direction of PCB.

(7) Anti radioactive ray design is not considered for the products.

(8) This device should not be used in any type of fluid such as water, oil, organic solvent etc. When washing is required, IPA should be used.

(9) When the LEDs are illuminating, operating current should be decided after considering the ambient maximum temperature.

(10) LEDs must be stored to maintain a clean atmosphere. If the LEDs are stored for 3 months or more after being shipped from SSC, a sealed container with a nitrogen atmosphere should be used for storage.

(11) The LEDs must be soldered within seven days after opening the moisture-proof packing.

(12) Repack unused products with anti-moisture packing, fold to close any opening and then store in a dry place.

(13) The appearance and specifications of the product may be modified for improvement without notice.

11. Reliability Test Item and Condition

Item	Reference	Test Condition	Duration / Cycle	Number of Damage
Thermal Shock	EIAJ ED-4701	$T_a = -40^{\circ}\text{C}$ (30MIN) ~ 100°C (30MIN)	100 Cycle	0/22
Temperature Cycle	EIAJ ED-4701	$T_a = -40^{\circ}\text{C}$ (30MIN) ~ 25°C (5MIN) ~ 100°C (30MIN) ~ 25°C (5MIN)	100 Cycle	0/22
High Temperature Storage	EIAJ ED-4701	$T_a = 100^{\circ}\text{C}$	1000 Hours	0/22
High Temperature High Humidity Storage	EIAJ ED-4701	$T_a = 85^{\circ}\text{C}$, RH=85%	1000 Hours	0/22
Low Temperature Storage	EIAJ ED-4701	$T_a = -40^{\circ}\text{C}$	1000 Hours	0/22
Operating Endurance Test	Internal Reference	$T_a = 25^{\circ}\text{C}$, $I_F = 20\text{mA}$	1000 Hours	0/22
High Temperature High Humidity Life Test	Internal Reference	$T_a = 85^{\circ}\text{C}$, RH=85%, $I_F = 15\text{mA}$	300 Hours	0/22
High Temperature Life Test	Internal Reference	$T_a = 85^{\circ}\text{C}$, $I_F = 20\text{mA}$	500 Hours	0/22
Low Temperature Life Test	Internal Reference	$T_a = -40^{\circ}\text{C}$, $I_F = 20\text{mA}$	1000 Hours	0/22
ESD(HBM)	MIL-STD-883D	1KV at 1.5k Ω ; 100pF	3 Time	0/22

□ Criteria for Judging the Damage

Item	Symbol	Condition	Criteria for Judgement	
			MIN	MAX
Forward Voltage	V_F	$I_F = 20\text{mA}$	-	USL*1 \times 1.2
Reverse Current	I_R	$V_R = 5\text{V}$	-	USL*1 \times 2.0
Luminous Intensity	I_V	$I_F = 20\text{mA}$	LSL*2 \times 0.5	-

Note : *1 USL : Upper Standard Level

*2 LSL : Lower Standard Level